

Pocket PLC with Ethernet/RS232

RIO-47xxx

Product Description

The RIO-47xxx is an intelligent programmable logic controller (PLC) with 100Base-T Ethernet capability. The RIO contains a fast RISC processor for handling I/O logic and is programmed using Galil's easy-to-use, two-letter command language or Ladder Interface Software.

Each RIO-471xx unit is self-contained with numerous analog and digital I/O including: 8 analog inputs, 8 analog outputs, 16 optically isolated inputs, 8 high-power isolated outputs and 8 low-power isolated outputs. Multiple RIO units can be distributed on an Ethernet network allowing I/O expansion.

The RIO receives power from Power-Over-Ethernet (PoE) or an external 18–36 VDC supply. Measuring just 3.88" × 4.26" × 1.30", the RIO-471xx is packaged in a compact metal enclosure and provides D-type connectors for convenient interface. Mating ICS boards provide screw terminals for fast proto-typing. Mating SCB signal conditioning boards allow interface to RTDs or thermocouples. The RIO-47200 is a DIN rail mount unit with screw terminals.

RIO-471xx Pocket PLC



RIO-47200 provides DIN mount and screw terminals

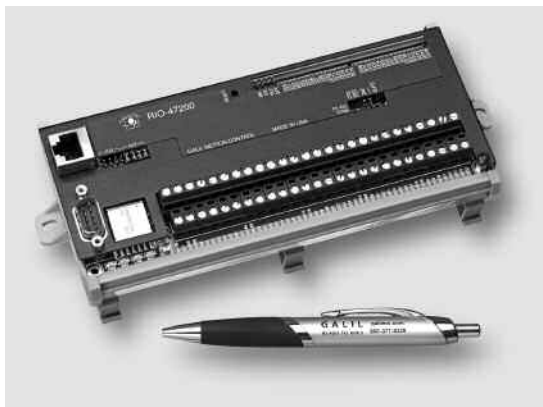

Features

- Intelligent, Remote Ethernet I/O Controller
- 10/100Base-T Ethernet Link and 115 kb RS232 port
- 8 analog inputs—
RIO-47100: 0-5 V; 12-bit ADC
RIO-47120: user configurable ± 10 V, ± 5 V, 0-10 V, 0-5 V
12-bit ADC standard, 16-bit optional
Accepts single-ended or differential
RIO-47200: 0-5 V; 12-bit ADC (± 10 V, 16-bit option)
- 8 analog outputs—
RIO-47100: 0-5 V; 12-bit DAC
RIO-47120: user configurable ± 10 V, ± 5 V, 0-10 V, 0-5 V
12-bit DAC standard, 16-bit optional
RIO-47200: Optional with SCB-48608
- 16 optically isolated inputs
- RIO-471xx: 8 high-power, isolated outputs rated at 500 mA per output
RIO-47200: 16 high-power, isolated outputs rated at 500 mA per output
- 8 isolated outputs rated at 25 mA max per output for RIO-471xx. Optional for RIO-47200
- LED indicators for all digital I/O points
- Contains RISC processor and non-volatile memory for programming I/O events
- Expanded variables, memory and control loops for RIO-471x2 option
- Easy-to-use, 2-letter Galil programming language
- Multitasking threads for simultaneous execution of multiple I/O programs
- Provides pulse counter and process loop control
- Option to read position sensors at 8 Mhz, at 25 msec intervals. Specify -QUAD, -SSI, or -BISS. For RIO-47122 only
- Web interface and email capability for sending messages
- Powered by Power-Over-Ethernet (PoE) or external 18–36 V DC input
- RIO-471xx: 3.88" x 4.26" x 1.30"
RIO-47200: 7.19" x 3.52" with DIN tray
- Metal Enclosure for RIO-471xx. DIN for RIO-47200
- D-type connectors for RIO-471xx.
Screw terminals for RIO-47200
- Modbus/TCP master or slave
- Galil's Ladder Interface Software is available for converting Relay Ladder Logic programs into deterministic code for the RIO
- RIO-471xx has ETL and CE certification
- Communication drivers for Windows, Mac OSX, and Linux

Pocket PLC Controller

RIO-47xxx

Specifications

System Processor

- RISC-based clock multiplying processor with DSP functions

Communications Interface

- 10/100Base-T Ethernet port
- RS232 port— 19.2 kbaud, 115 kbaud

Memory (RIO-471x0 and RIO-47200)

- Program memory size: 200 lines x 40 characters
- 126 variables
- 400 array elements in up to 6 arrays
- 2 PID control loops
- 3 Ethernet handles

Memory (RIO-471x2)

- Program memory size: 400 lines x 40 characters
- 254 variables
- 1000 array elements in up to 6 arrays
- 6 PID control loops
- 5 Ethernet handles

I/O

- Digital Outputs 0–7 are opto-isolated sourcing power outputs. 12–24 VDC, 500 mA* for RIO-471xx. 0–15 for RIO-47200
- Digital Outputs 8–15 are opto-isolated sinking outputs. 5–24 VDC, 25 mA for RIO-471xx
- Digital Inputs 0–15 are opto-isolated inputs. 2.2 K series resistor for 5–24 V input
- 8 analog inputs—
RIO-47100 and -47200: 0–5 V; 100 K input impedance; 12-bit ADC
RIO-47120: user configurable ± 10 V, ± 5 V, 0–10 V, 0–5 V
12-bit ADC standard, 16-bit optional
Single-ended: 42 K input impedance
Differential: 31 K input impedance
- 8 analog outputs—
RIO-47100: 0–5 V; source/sink up to 4 mA; 12-bit DAC
RIO-47120: user configurable ± 10 V, ± 5 V, 0–10 V, 0–5 V
12-bit DAC standard, 16-bit optional; source/sink up to 4 mA
RIO-47200: Optional with SCB-48608. 12- or 16-bit DAC.

Power

- PoE (Power over Ethernet) or External Power
- Power consumption is 2.5 Watts typical, 4 Watts max.
- External Input is 18 to 36 VDC

Mechanical

- RIO-471xx: 3.88" x 4.26" x 1.30"
- RIO-47200: 7.19" x 3.52" with DIN tray

Environmental

- Operating Temperature: 0–70 °C

*Requires external DC supply.

Connectors for RIO-471xx

Serial

9-pin; Male connector and cable

- 1 NC
- 2 Transmit data-output
- 3 Receive data-input
- 4 NC
- 5 Ground
- 6 NC
- 7 Clear to Send-input
- 8 Request to Send-output
- 9 NC

Analog I/O

26-pin HD Female D-sub

- 1 NC
- 2 NC
- 3 Analog input 7
- 4 Analog input 4
- 5 Analog input 1
- 6 Analog Ground
- 7 Analog output 5
- 8 Analog output 2
- 9 Analog Ground
- 10 NC
- 11 NC
- 12 Analog Ground
- 13 Analog input 5
- 14 Analog input 2
- 15 Analog Ground
- 16 Analog output 6
- 17 Analog output 3
- 18 Analog output 0
- 19 NC
- 20 NC
- 21 Analog input 6
- 22 Analog input 3
- 23 Analog input 0
- 24 Analog output 7
- 25 Analog output 4
- 26 Analog output 1

Digital I/O

44-pin HD Female D-sub

- 1 Digital Input 15
- 2 Digital Input 12
- 3 Digital Input 9
- 4 NC
- 5 Digital Input 6
- 6 Digital Input 3
- 7 Digital Input 0
- 8 Output Common OP1B—Power (Outputs 8-15)
- 9 Digital Output 13
- 10 Digital Output 10
- 11 Output Common OP1A—Ground (Outputs 8-15)
- 12 Digital Output 7
- 13 Digital Output 4
- 14 Digital Output 1
- 15 Output Common OP0A—Power (Outputs 0-7)
- 16 NC
- 17 Digital Input 13
- 18 Digital Input 10
- 19 Input Common 1 (Inputs 8-15)
- 20 Digital Input 7
- 21 Digital Input 4
- 22 Digital Input 1
- 23 NC
- 24 Digital Output 14
- 25 Digital Output 11
- 26 Digital Output 8
- 27 Output Common OP0B—Ground (Outputs 0-7)
- 28 Digital Output 5
- 29 Digital Output 2
- 30 Output Common OP0A—Power (Outputs 0-7)
- 31 Digital Input 14
- 32 Digital Input 11
- 33 Digital Input 8
- 34 NC
- 35 Digital Input 5
- 36 Digital Input 2
- 37 Input Common 0 (Inputs 0-7)
- 38 Digital Output 15
- 39 Digital Output 12
- 40 Digital Output 9
- 41 NC
- 42 Digital Output 6
- 43 Digital Output 3
- 44 Digital Output 0

External Power

- 1 Ground
- 2 18-36VDC

Instruction Set

Ethernet

DH	DHCP enable
HS	Handle assignment switch
IA	Set IP address
IH	Internet handle
MA	Email server IP address
MB	Modbus
MD	Email destination address
MI	Modbus Integer
MS	Email source address
MV	Modbus Reversal
MW	Modbus wait
SA	Send command
SM	Subnet mask

I/O

AO	Analog output voltage
AQ	Analog configuration
CB	Clear bit
II	Input interrupt
IQ	Input configuration
OB	Define output bit
OP	Output port
PC	Pulse counter enable
SB	Set bit
@AN[x]	Value of analog input x
@AO[x]	State of analog output x
@IN[x]	State of digital input x
@OUT[x]	State of digital output x

Interrogation

ID	Identify
LA	List arrays
LL	List labels
LS	List program
LV	List variables
MG	Message command
QR	Data record
QU	Upload array
QZ	Return data record information
^R^V	Revision
TB	Tell status byte
TC	Tell error code
TE	Tell Error
TH	Tell Ethernet handles
TI	Tell input
TIME	Time operand, internal clock
TR	Trace program
TZ	Tell I/O configuration
WH	Ethernet handle

Math Functions

@SIN[x]	Sine of x
@COS[x]	Cosine of x
@COM[x]	1's complement of x
@ASIN[x]	Arc sine of x
@ACOS[x]	Arc cosine of x
@ATAN[x]	Arc tangent of x
@ABS[x]	Absolute value of x
@FRAC[x]	Fraction portion of x
@INT[x]	Integer portion of x
@RND[x]	Round of x
@SQR[x]	Square root of x
@TAN[x]	Tangent of x
\$	Hexadecimal
()	Parenthesis
+, -, *, /, %	Arithmetic commands
>, <, =, >=, <=, <>	Logical operators
&	Logical AND
	Logical OR

Control Loop

AF	Analog feedback select
AZ	Analog output select
CL	Control loop update rate
DB	Deadband
IL	Integrator limit
KD	Derivative constant
KI	Integrator constant
KP	Proportional constant
OF	Offset
PS	Control set point

Programming

`	Continuation character
'	Comments
#	Label
#AUTO	Auto subroutine on power-up
#AUTOERR	Auto subroutine on EEPROM error
#TCPERR	Auto subroutine on Ethernet error
#CMDERR	Auto subroutine on command error
#COMINT	Auto subroutine on communication interrupt
#ININT	Auto subroutine on input interrupt
[]	Array index operator
;	Command delimiter
AB	Abort program
BK	Breakpoint
CI	Communication interrupt
DA	Deallocate variables/arrays
DL	Download program
DM	Dimension arrays

Programming (cont.)

ED	Edit program
ELSE	Conditional statement
EN	End program
ENDIF	End of conditional statement
HX	Halt execution
IF	If statement
IN	Input variable
JP	Jump
JS	Jump to subroutine
NO	No-operation — for comments
RA	Record array, automatic data capture
RC	Record interval for RA
RD	Record data for RA
RE	Return from error
REM	Remark
RI	Return from interrupt routine
SA	Send command
SL	Single step
UL	Upload program
XQ	Execute program
ZC	User variable
ZD	User variable
ZS	Zero stack

System Configuration

BN	Burn parameters
BP	Burn program
BV	Burn variables and arrays
CC	Configure communication port
CF	Configure default port
CI	Configure communication interrupt
CW	Data adjustment bit
DR	Configure I/O data record
EO	Echo off
IK	Ethernet port blocking
^L^K	Lock program
LZ	Leading zeros format
PW	Password
QD	Download array
QU	Upload array
RS	Reset
^R^S	Master reset
VF	Variable format

Trippoint

AA	After analog input
AI	After input
AT	At time
WT	Wait for time

Pocket PLC Controller

RIO-47xxx

Ladder Interface Software

Galil's Ladder Interface Software is a software tool for the RIO-47xxx Pocket PLC. The software converts a relay Ladder Logic program into code for input into the RIO controller. Ladder Logic is often used by programmable logic controller (PLC) programmers to graphically input I/O logic. While direct RIO programming using Galil's two-letter text instructions allows for flexible coding, it is sometimes easier to determine the I/O logic visually with Ladder Logic.

The Ladder Interface Software provides an easy-to-use graphical interface that allows object types for: contacts, coils, control relays, boxes (including timers, counters and data manipulation) and analog I/O. The software generates an RIO program from the specified objects in the flow diagram. In addition to generating optimized code, Galil's Ladder Interface Software automatically adds determinism to the RIO program.

Features

- Object types include:
 - Contacts
 - Coils
 - Control relays (virtual contacts/coils)
 - Boxes (including timers, counters and data manipulation)
 - Analog I/O
- Standard mathematical and logical operators include:
 - Equal, Not Equal, Less than, Greater than
 - AND, OR (normally open or normally closed)
 - Add, Subtract, Multiply, Divide, Increment, Decrement
 - Shift or rotate accumulator left or right
- Galil command box for specifying any valid Galil two-letter command

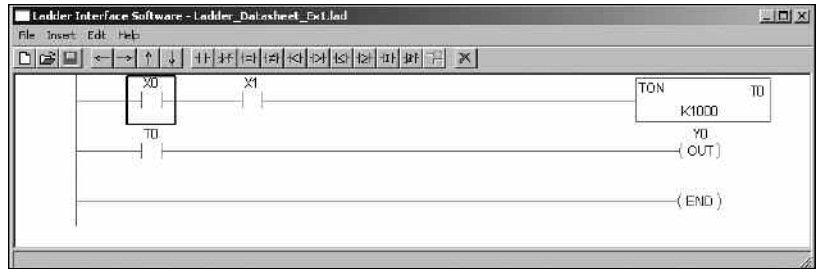

On-Timer (TON) Ladder Logic Example

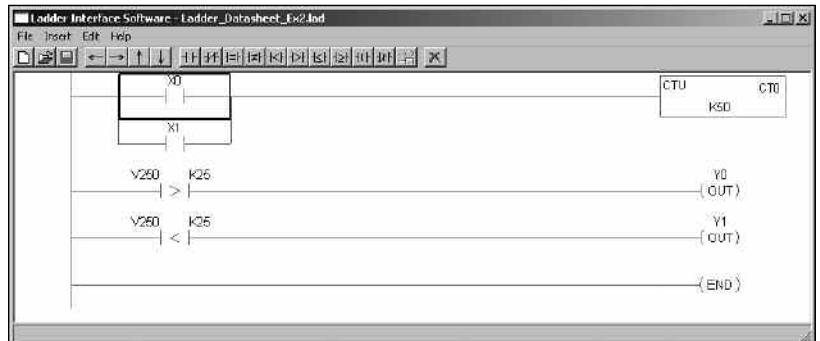

Up-Counter (CTU) and comparative logic example

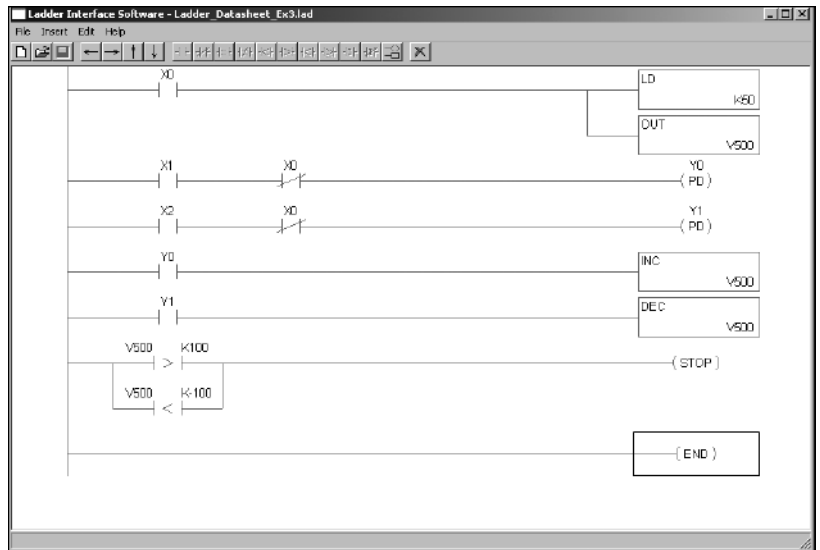

One-shot output (PD) and variable manipulation example

Pocket PLC Controller

RIO-47xxx

High Power Sourcing Outputs (RIO-471xx: 0–7, RIO-47200: 0–15) Opto-isolated sourcing power outputs. 12–24 VDC with 500 mA of current capability per output

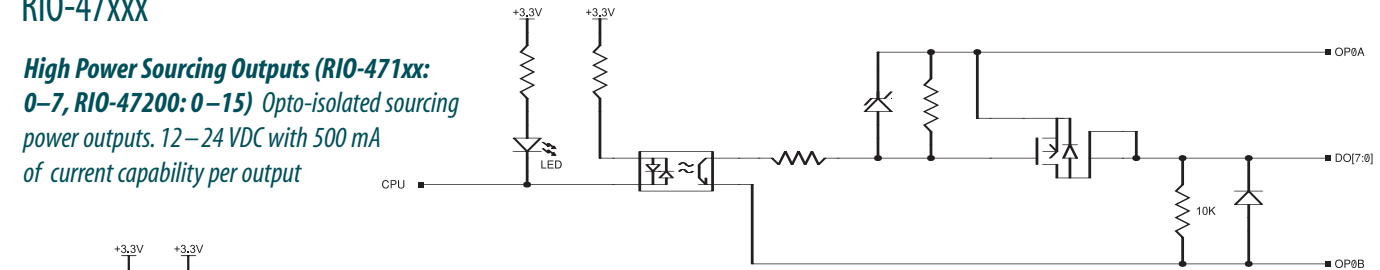

Low Power Sinking Outputs (RIO-471xx: 8–15) Opto-isolated sinking outputs. 5–24 VDC with 25 mA of current capability in a sinking configuration

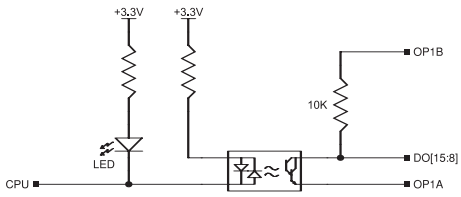

Digital Inputs: Digital inputs 0–15 are opto-isolated inputs with a range of 5–24 VDC

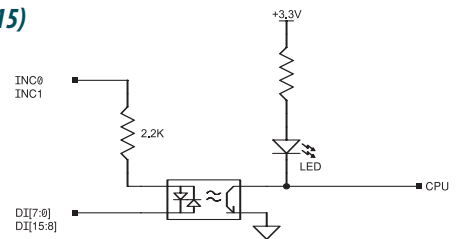

Ordering Information

PART NUMBER	DESCRIPTION	QUANTITY 1	QUANTITY 100
RIO-47100	PLC with 0–5 V analog I/O; 12-bit ADC/DAC	\$ 295	\$ 195
RIO-47120	PLC with ±10 V analog I/O; 12-bit ADC/DAC	\$ 345	\$ 245
RIO-4712x-16	16-bit ADC/DAC option for RIO-47120 or -47122	add \$ 50	add \$ 50
RIO-47102	RIO-47100 with expanded memory	\$ 345	\$ 245
RIO-47122	RIO-47120 with expanded memory	\$ 395	\$ 295
-DIN	DIN-rail mounting option for RIO-471xx	\$ 25	\$ 25
RIO-47200	RIO with screw terminals and DIN. 12-bit, 0–5 VDC analog inputs. Consult factory for additional analog I/O options (±10 V, 16-bit)	\$ 345	\$ 245
SCB-48608-5V12bit	-47200 Option for 8 analog outputs. 12-bit DAC; 0-5 V. Specify RIO-47200-8AO_5v12bit	add \$ 50	add \$ 30
SCB-48608-10V12bit	-47200 Option for 8 analog outputs. 12-bit DAC; 0-5 V, 0-10 V, ±10 V. Specify RIO-47200-8AO_10v12bit	add \$ 75	add \$ 45
SCB-4860-10V16bit	-47200 Option for 8 analog outputs. 16-bit DAC; 0-5 V, 0-10 V, ±10 V. Specify RIO-47200-8AO_10v16bit	add \$ 120	add \$ 80
SCB-48206	Signal conditioning board for interface to 6 RTDs	\$ 175	\$ 125
SCB-48306	Signal conditioning board for interface to 6 thermocouples	\$ 175	\$ 125
SCB-48316	Above with thermocouple connectors	\$ 225	\$ 175
CABLE-44-1M	44-pin D HD male cable to discrete wires	\$ 35	\$ 24
CABLE-26-1M	26-pin D HD male cable to discrete wires	\$ 25	\$ 17
ICS-48026-M	26-pin D HD male to screw terminals	\$ 75	\$ 50
ICS-48044-M	44-pin D HD male to screw terminals	\$ 75	\$ 50
-HS	High-speed counter option, 3 MHz	\$ 25	\$ 0
-422	RS422 option	\$ 25	\$ 0
-QUAD, -BiSS, -SSI	Position sensor option for RIO-47122	\$ 75	\$ 35
4-20mA	For 4-20mA analog inputs	add \$ 10	
PS-0.25-24	24 V, 6-watt power supply for RIO	\$ 50	\$ 35
PS-2.50-24	24 V, 60-watt power supply for RIO	\$ 85	\$ 60
Ladder Interface Software	Converts Relay Ladder logic into deterministic code for RIO	\$ 195	
GalilTools-Lite	Editor, Terminal, Watch Tools. Includes communication library for developers-supports C++, VB, C#, LabVIEW and more	Free download	
GalilTools	Above with Scope and Tuner	\$ 195	

Galil offers additional quantity discounts for purchases between 1 and 100. Consult Galil for a quotation.