

Application Note #1254

DMC-21x3 J4/J5 Pin Numbering

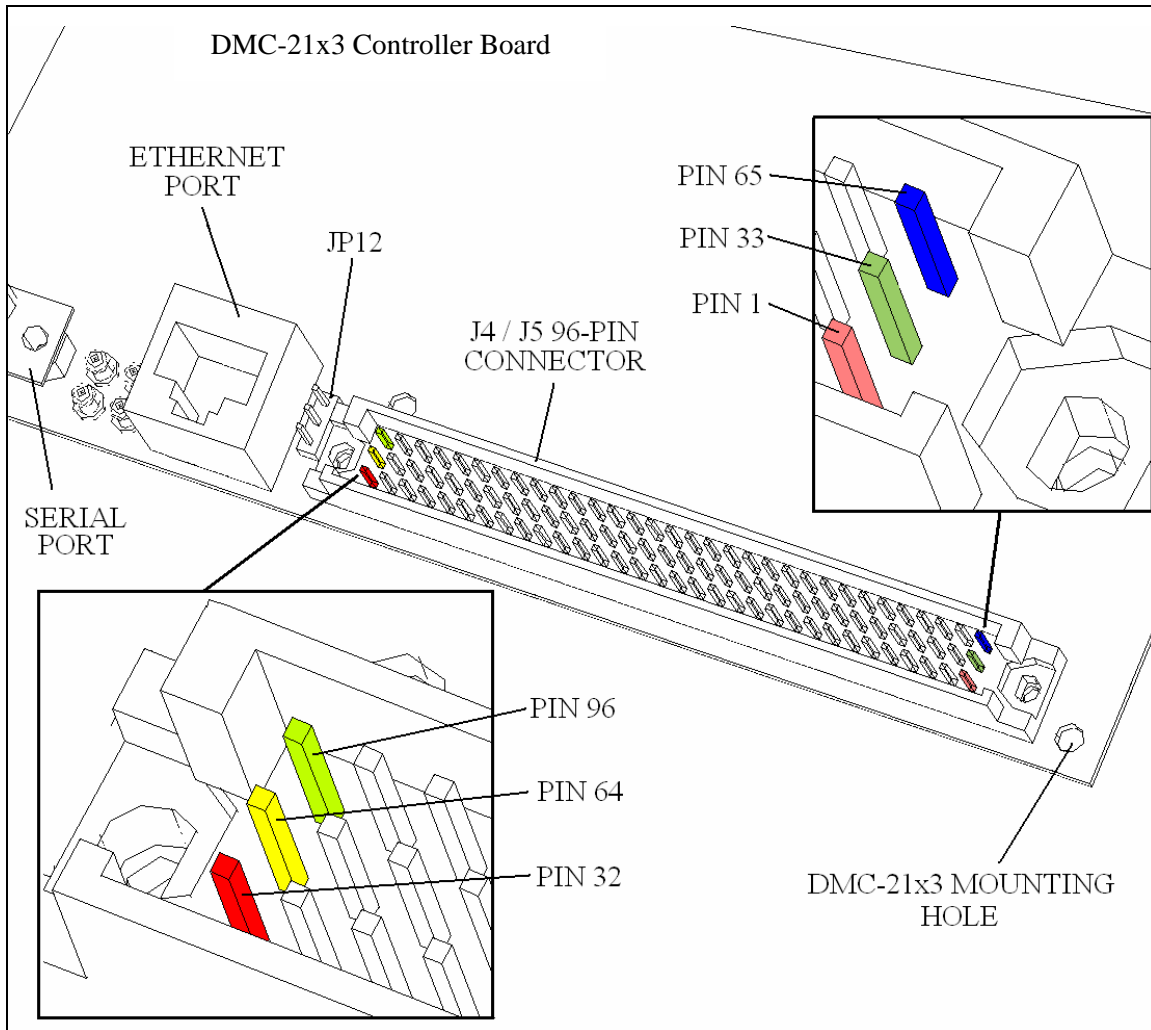

Figure 1 – DMC-21x3 J4 and J5 plug in -UP (default) configuration.

The 96-pin connector (J4 & J5 on the DMC-21x3 controller) has 'A1' embossed into the plastic in the bottom left corner (PIN 32). This embossment should be disregarded. The proper pin numbering is shown in Figure 1. If the controller board is flipped over, the silkscreen next to the solder joints clearly indicates the pin numbering. Alternate orientations of the 96-pin connector can be ordered and the numbering is shown in Figures 2 and 3.

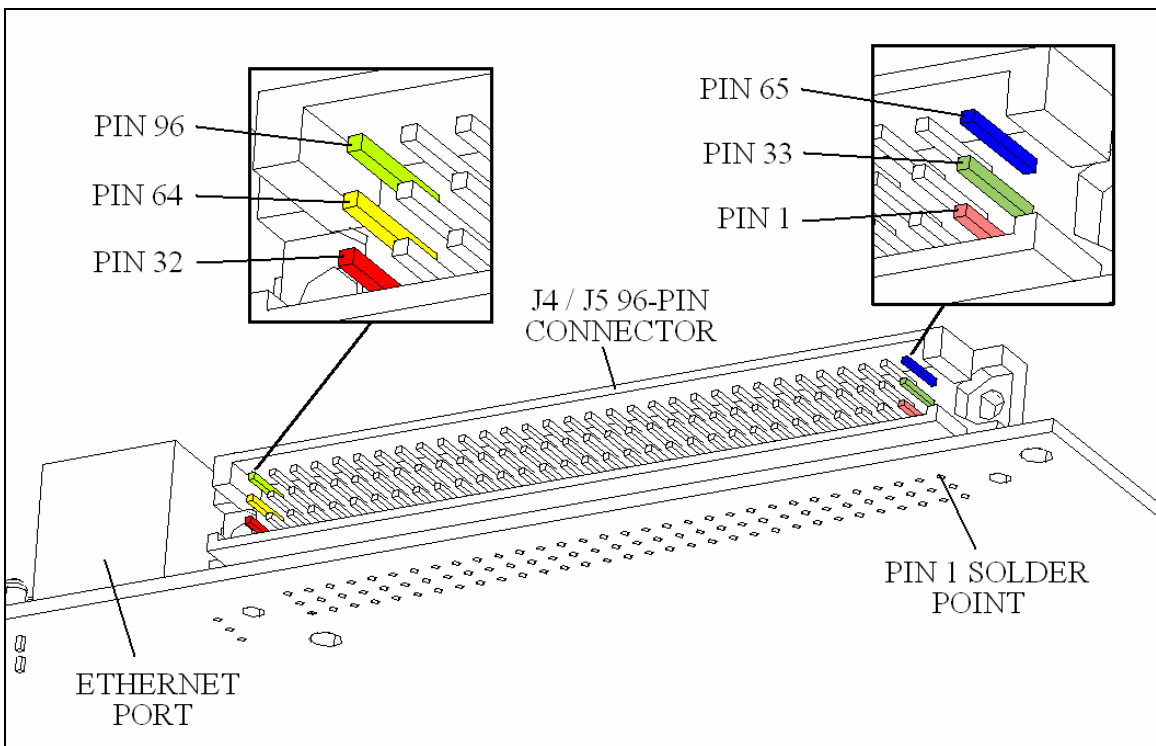

Figure 2 – DMC-21x3 J4/J5 –RA (right angle) configuration.

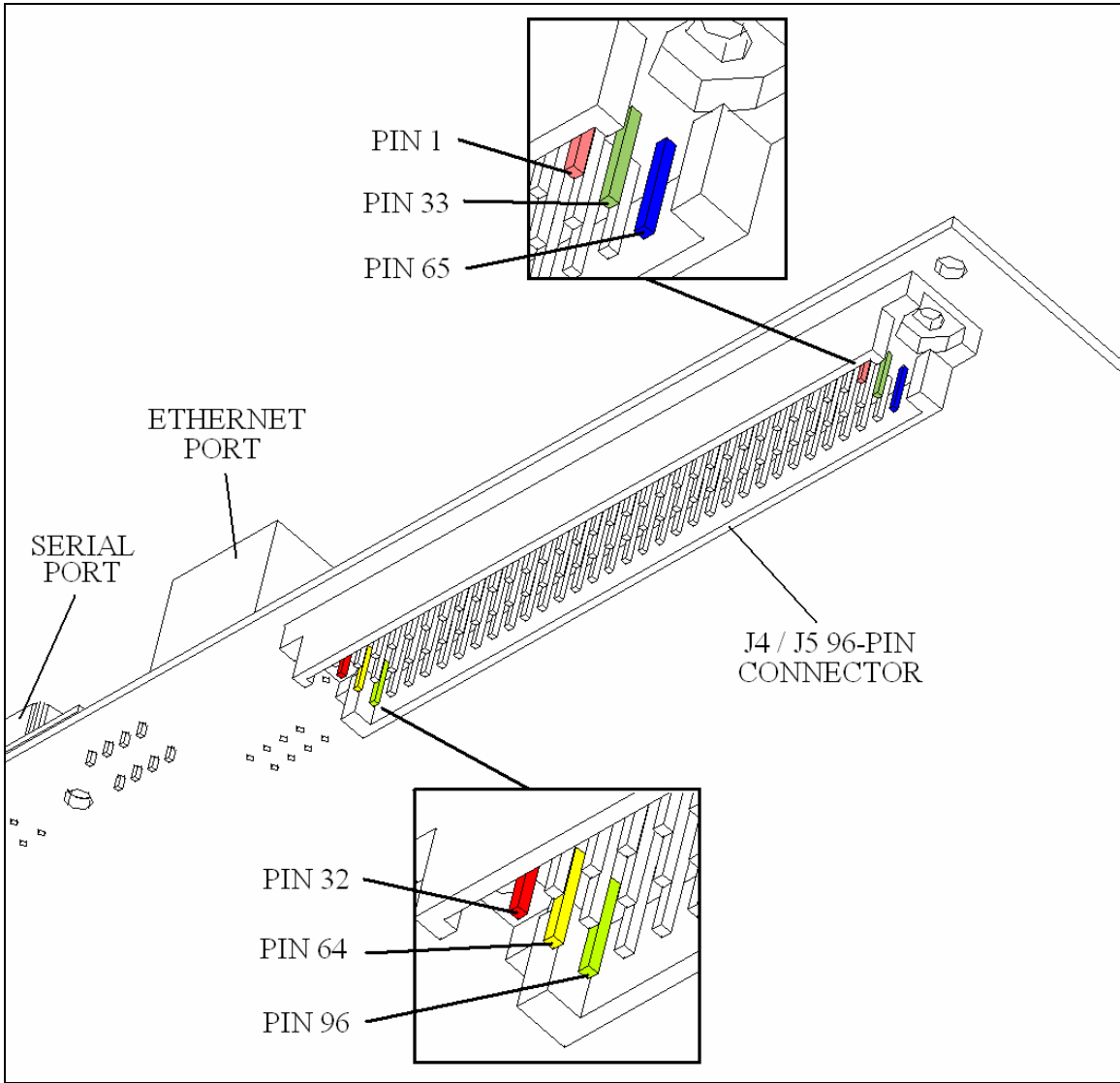

Figure 3 – DMC-21x3 J4/J5 –DOWN configuration.